

Replacement Proposal of existing Controller

The example of a replacement proposal of a HYROP(3microcomputer) hydraulic controller is shown below.

Existing controller

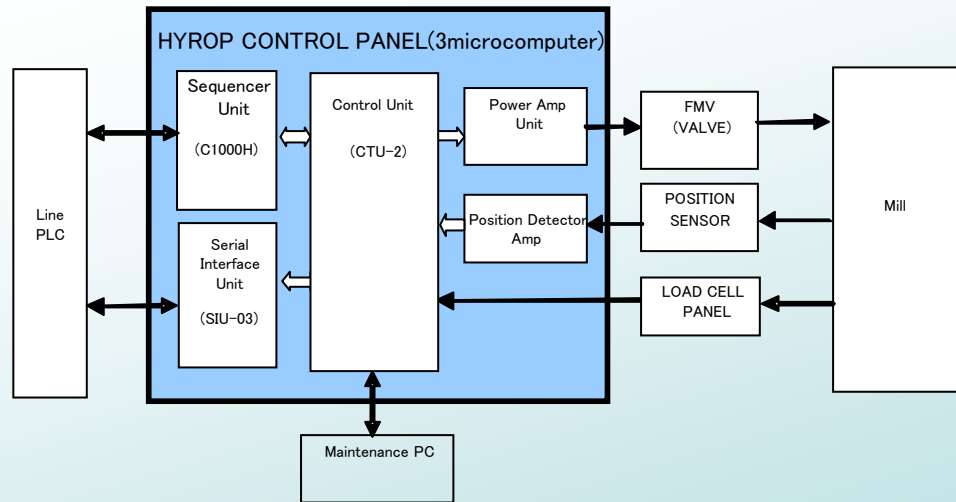

Replacement proposal of controller

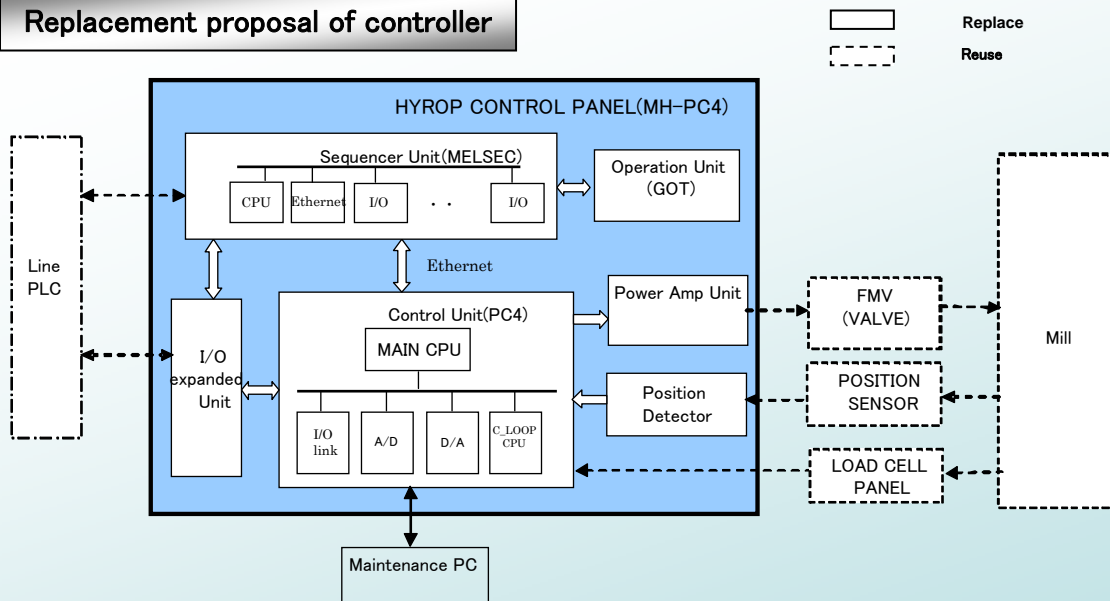

<Contents of replacement>

- 1) Removal of an existing control panel
- 2) Installation of a new control panel
- 3) Wiring work (wiring about a new control panel)
- 4) H/W and S/W remodeling of line PLC(if necessary)
- 5) The test after replacement, and online adjustment etc

* We also propose the replacement of sensor and actuator.