

9. Replacement Proposal of existing Controller

We propose the optimal replacement for every existing system.

The example of a replacement proposal of a rolling mill hydraulic controller is shown below.

Existing controller

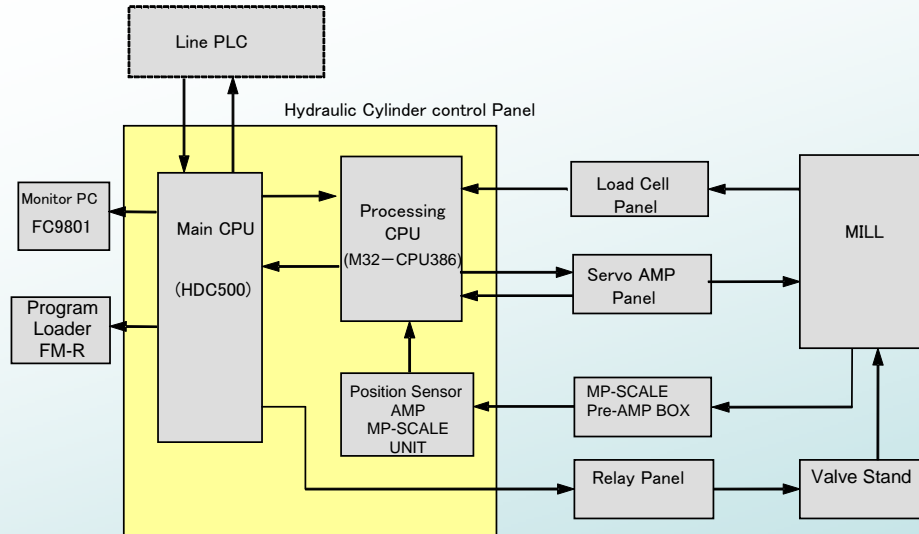

Replacement proposal of controller

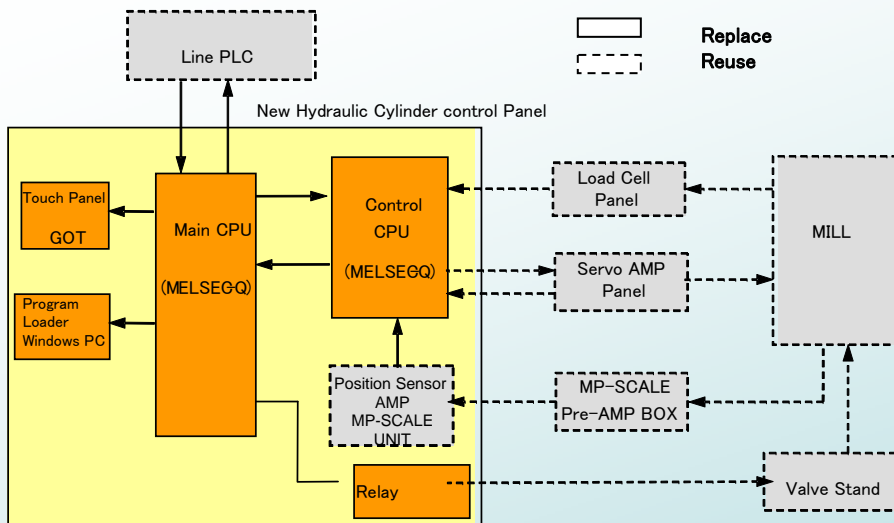

<Contents of replacement>

- 1) Removal of an existing control panel
- 2) Installation of a new control panel
- 3) Wiring work (wiring about a new control panel)
- 4) H/W and S/W remodeling of line PLC(if necessary)
- 5) The test after replacement, and online adjustment etc

<Restrictions at the time of updating>

- 1) Monitor PC is replaced and set to GOT for MELSEC, and is installed in the front of control panel.
- 2) By restrictions of H/W of a new control panel, H/W and S/W by the side of line PLC may need partial to be changed.

* We also propose the replacement of sensor and actuator